



TENDER DOCUMENT FOR THE SUPPLY OF HVLS FANS AND INDUSTRIAL COOLERS.

TENDER DOC NO: AIESL/PPMM/HVLS/INDCLR/23-24/23069

Date:05-10-2023

NAME & ADDRESS OF THE AGENCY/CONTRACTOR

M/s.....

.....

.....

Phone : _____

Email : _____

Scan for address



AIESL
ENGINEERING SERVICES LIMITED

SD/-
General Manager
AIESL

TABLE OF CONTENTS

S. No.	DESCRIPTION
1	NOTICE INVITING TENDER (NIT)
2	DISCLAIMER
3	NOTICE TO BIDDER (NTB)
4	INSTRUCTIONS TO BIDDER (ITB)
5	GENERAL TERMS AND CONDITIONS (GTC)
6	SPECIAL TERMS & CONDITIONS(STC)
7	AWARD DECISION FOR L1
8	TECH.-COMM. BID ANNEXURE A
9	PRICE BID ANNEXURE B
10	DECLARATION ANNEXURE C
11	UNDERTAKING ANNEXURE D
12	Chartered Accountant's Certification Annexure E
13	Layout (Drawings) Annexure F

1. NOTICE INVITING TENDER (NIT)

Tender for the supply of HVLS Fans And Industrial Coolers.

Schedule Of Tender

TENDER NO	AIESL/PPMM/HVLS/INDCLR/23-24/23069
SCOPE OF WORK	SUPPLY OF HVLS FANS AND INDUSTRIAL COOLERS
TENDER ISSUER	AI ENGINEERING SERVICESLIMITED
DATE OF ISSUE OF TENDER DOCUMENT	05TH October 2023.
LAST DATE OF SUBMISSION OF BIDS	16th October 2023 by or before 14:00 Hrs
VALIDITY OF BID	120 days from the date of opening of technical bid.
PRE BID MEETING / SITE VISIT	09th October 2023 at 10:30 Hrs
DATE OF OPENING OF TECH. BIDS	16th October 2023 at 14:30 Hrs
DATE OF OPENING OF PRICE BID	WILL BE INTIMATED TO TECHNICALLY QUALIFIED BIDDERS
PLACE OF SUBMISSION & OPENING OF BIDS	Office of Dy General Manager Production planning & Material Management ,IGI AIRPORT T2 Delhi 110037, India, BOX NO. 2 https://goo.gl/maps/GZsFZBi6mAQ8hj728

ABREVIATIONS:

1	AIESL	AI ENGINEERING SERVICES LIMITED
2	HVLS	HIGH-VOLUME/LOW-SPEED
3	PBG	PERFORMANCE BANK GUARANTEE
4	EMD	EARNEST MONEY DEPOSIT
5	DAP	DELIVERY AT PLACE
6	LOA	LETTER OF AWARD
7	OEM	ORIGINAL EQUIPMENT MANUFACTURER
8	PO	PURCHASE ORDER
9	QTY	QUANTITY

2. DISCLAIMER

1. The information contained in this tender document (hereinafter referred to as the “Tender”) or and any information pertaining to the aforesaid subject matter provided subsequently to the applicants/bidders in any form by AIESL – AI Engineering Service Limited (hereinafter referred to as “AIESL”) shall be subject to the terms and conditions to which such information is provided contained herein and any other terms and conditions as may be prescribed by AIESL prior to award of the tender.

2. The purpose of this tender is to provide all bidders with the information that may be useful to them in the formulation of their proposals/bids (hereinafter referred to as “BID(S)”) in response to this tender. The statements and facts contained herein, which reflect various assumptions and assessments arrived at by AIESL do not purport to contain exhaustive /all the information on the aforesaid subject matter that each applicant may require for the purpose of submitting their bids.

3. Each bidder should, conduct its own due diligence, investigations and analyses and should check the accuracy, adequacy, correctness, reliability and completeness of the assumptions, assessments, and information contained in this tender and shall obtain independent advice from appropriate sources at no cost to AIESL.

4. The information provided in this tender to the applicants is on a wide range of matters, some of which depends upon interpretation of law. The information given is not an exhaustive account of statutory requirements and should not be regarded as a complete or authoritative statement of law. AIESL accepts no responsibility for the accuracy or otherwise for any interpretation or opinion on the law expressed herein.

5. AIESL also accepts no liability of any nature whether resulting from negligence or otherwise, however caused arising from reliance by any applicant/bidder upon the statements contained in this tender.

6. AIESL may, in its absolute discretion, but without being under any obligation to do so, update, amend or supplement the information, assessment or assumption contained in this tender, from time to time till the close date of the tender.

7. The tender does not imply that AIESL is bound to select a bidder or to appoint the selected bidder and AIESL reserves the right to reject all or any of the bid without assigning any reason whatsoever at any time.

8. The bidder shall bear all its costs associated with or relating to the preparation & submission of its bids including but not limited to preparation, copying, postage, delivery fees, expenses associated with any demonstrations or presentations which may be required by AIESL, or any other costs incurred in connection with or relating to in bids. All such costs and expenses shall remain with the bidder and AIESL shall not be liable in any manner whatsoever for the same or any other costs or other expenses incurred by the bidder in preparation for submission of the bid, regardless of the conduct or outcome of the bid selection process as contained herein.



3. NOTICE TO BIDDER (NTB)

3.1 Introduction:

AI Engineering Services Ltd (AIESL) the biggest DGCA (Directorate General of Civil Aviation) approved MRO Set up in India that can serve as a one-stop-shop for all engineering requirements at major Airports with pan India footprint i.e., Delhi, Mumbai, Hyderabad, Thiruvananthapuram, Kolkata, Nagpur etc. With a great skill set, huge professional experience and competency, AIESL manages and maintains Airbus, Boeing & ATR's fleet with the Technical Dispatch Reliability of more than 99%. With major hangars and bases located at all the major metros.

3.1.1. Vision & Mission

- 1) To provide best in class and timely quality services to the customers by maintaining highest standards of regulatory and safety compliance.
- 2) Maintaining all aircraft of the captive workload of the feet of Reputed Airlines in a continuous state of airworthiness by the system of preventive and corrective maintenance to secure a high level of safety.
- 3) Provide a “One Stop” solution to the customer.
- 4) Faster Turn Around Time.
- 5) To capture maximum Third-Party work from in and around India
- 6) Aggressive Marketing policy for more and more third-party work.
- 7) Continuous monitoring of Quality through quality audit etc.
- 8) Constant endeavor to upgrade the services, delivering highest customer satisfaction in terms of Quality, Service and Cost effective and ensuring long term strategic relationship.
- 9) All-out effort to be the world class MRO without compromising the quality standard.
- 10) Updating and enhancing the capability through training of the personnel and equipment of latest technology.

This request for quotes is issued to invite quote/proposal from OEM/ manufacturers / authorized distributors for supply HVLS FANS AND INDUSTRIAL COOLERS at General Manager - Engineering, AI ENGINEERING SERVICES LIMITED, Production Planning & Materials Management, Northern Region, New Avionics Complex, IGIA Terminal 2, New Delhi 110037.

AIESL invites sealed bids in a two-bid stage system i.e.

- I. Technical Bid
- II. Price Bid.

The first stage of the bidding process shall involve the opening of the Technical bid Response and the second stage shall involve the opening of the Financial Bid Response after technical bid evaluation.

3.2 WORKSCOPE:

Supply of HVLS fans and industrial coolers as per specifications mentioned in Techno-commercial Bid.

3.3.1. Delivery Point/Receipt terms & conditions:-

Delivery of item/equipment should be at DAP (Delivery at Place) General Manager - Engineering, AI ENGINEERING SERVICES LIMITED, Production Planning & Materials Management, Northern Region, New Avionics Complex, IGIA Terminal 2, New Delhi 110037.



Landmark Gate No.6 Cargo . New Custom House.

3.3.2. Delivery Schedule:-

The unit must be delivered of equipment preferably within **one month (Mandatory)** from the date of receipt of LOA/PO.

4. INSTRUCTIONS TO BIDDER (ITB)

General Instructions

The bid shall be furnished in two-part bidding basis i.e., Technical-bid and Financial Bid. The complete tender can be downloaded from AIESL's website. www.aiesl.in

Instructions for bid submission: General Manager-Engineering invites Manual/Hard copy bids under Two Bid System.

Bidders shall submit their offer, in two separate sealed envelopes, as is required of the two bid tender system. Later both envelopes must put in master envelop (seal master envelop).

4.1 Technical Bid (ENVELOP COVER – I)

The first envelope should be super-scribed with the tender reference number and be marked as “Technical Bid – SUPPLY OF HVLS FANS AND INDUSTRIAL COOLERS Tender Reference: **AIESL/PPMM/HVLS/INDCLR/23-24/23069** dtd. “.....” on or before 14:00 Hrs and must contain the following:

- Complete tender document with signature and seal of Bidder (All Annexures, other documents as requested in tender document).
- EMD in form of Bankers Demand Draft to be enclosed, mandatory to non MSME/NSIC bidders). Foreign bidders can submit online (for more details refer commercial terms).
- To EMD exemption kindly enclosed hard copy of same service to claim.
- EMD DD or MSME/MSIC cert. to be enclosed in separate small size envelope.
- Envelop must contain the following: Tech Bid for supply of HVLS fans and industrial coolers
- Bidder must submit tender document in Spiral binding with separator as per Index.
- Bidders should submit a copy of their price bid response **WITHOUT MENTION OF ANY PRICE WHETHER IN FIGURES OR WORDS** (with price blanked) along with the Technical Bid
- Financial Document (Company Existence/Details eg. GST Reg. Cert. Pan Card, ITR, Profit Loss sheet with computation hard copies, Company Details, EMD fees/MSME Certificate, all technical documents as requested in tender document).
- While enclosing all annexures in tech bid envelop it is requested that pages must be numbered for eg. 1 of xx pages (pg no. hand written/typed both are acceptable)
- Non Compliance to above conditions will lead to disqualification from points a to i.
- Bids preferably must be submitted in spiral binding of A4 page with soft copy in pen drive.

4.2 Price Bid (COVER – II)

The second envelope should be super-scribed with the tender reference number and be marked as “Price Bid - “Not To Be Opened Before or with Technical Bid” Tender Enquiry **AIESL/PPMM/HVLS/INDCLR/23-24/23069** Dtd. “.....” for “SUPPLY OF HVLS FANS AND INDUSTRIAL COOLERS” and should contain only the Price offer.

The rate along with the complete details of applicable taxes and any other charges as per **Annexure B**. The rates should be written in figures as well as words. In case there is mismatch in rates quoted in figures and words, the amount in words shall prevail.

Bidder can enclosed Price Bid Page only, no requirement putting complete tender



document.

(Non Compliance to above conditions will lead to disqualification).

4.3 Master Envelop (Cover –III)

The two sealed envelopes i.e., **Technical Bid (Envelop 1) and one Price Bid (Envelop II)** should be further put in a Master Envelope super scribed with “Tender Reference: TENDER REF. No. **AIESL/PPMM/HVLS/INDCLR/23-24/23069** due on Dtd. “....” on or before 14:00 Hrs. The above should be submitted at the following:

**O/o Dy. General Manager (E-PPMM)
AI ENGINEERING SERVICES LTD,
NEW AVIONICS COMPLEX,T-II,
IGI AIRPORT,DELHI-110037,India.
(Drop Bids in Box No.2)**

Google Maps link:

<https://goo.gl/maps/GZsFZBi6mAQ8hj728>

No deviation of the above will be accepted



4.4.1 Bid opening procedure for bidders:

Sealed bids will be opened as per time schedule mentioned herein in this tender document.

Bidder(s) can view Bid opening event in person or over online call at their end. In the event of the Specified date for the opening of bids being declared a holiday for AIESL, the Bids will be opened at the appointed time and location on the next working day.

Technical Bids (i.e., Part-I) shall be opened first.

Part-I i.e., Technical Bids shall be evaluated for establishing eligibility of the bidder as well as techno-commercially responsiveness as per bid conditions, and a list will be drawn up of the responsive bids whose financial bids are eligible for consideration.

The Part-II i.e. Financial Bid of only those Bidder(s), who are found to be meeting the eligibility criteria as well as techno-commercially responsive for the subject Works shall be opened thereafter. The date of opening of the Financial Bid shall be notified separately to all the eligible & techno-commercial responsive Bidder.

Bidder(s) can view Bid opening event in person or over online call at their end.

The Financial Bids of Bidder(s), who are not considered eligible and techno-commercially responsive, shall not be opened. The decision of AIESL will be final and binding in this regard.

The bids should be neatly presented. No overwriting or cutting/usage of white correction ink would be accepted in the Tender Document. Corrections, if any, should be duly authenticated with full signature of the authorized person who is signing the Tender, failing which the Tender is liable to be rejected.

AIESL reserves the right to award the contract(s) to Successful Bidder as it may deem fit as per its operational requirements.

4.4.2 Amendments (If Any)

Amendments, corrigendum, clarifications and due date extension if any, to this Tender will be hosted on the web site of AIESL, (www.aiesl.in) and no separate Notice Inviting Tender (NIT) would be issued in the newspapers or anywhere else.

AIESL will also not intimate the Bidders individually of the same. The Bidders are therefore, advised to visit the AIESL website regularly till the date of closing of the Tender (or extended date, if any). The last amendment, if any, will be hosted a minimum of seven (07) days before the closing date of the Tender.

4.4.3 Modification Of Bids

- i. On account of any amendments, being made to the Tender the Bidders shall have a right to modify their bid after the bid submission but prior to the due date (or extended due date, if any) for submission of Bid. The last modified bid of the Bidder received by AIESL before the due date (or extended due date, if any) and as submitted to AIESL shall be final and binding on the Bidder.
- ii. The modification shall also be prepared, sealed, marked and dispatched in accordance with the provisions of this Tender, with the outer and inner envelopes additionally marked “modification”. No bid shall be modified after the deadline for submission of bids.
- iii. At any time prior to the last date for submission of bids, AIESL may for any reason, whether at its own initiative or in response to a clarification requested by a prospective Bidder, modify this Tender document by an amendment. In order to afford reasonable time to Bidders to take such amendments into account for preparation and submission of their bids, AIESL may, at its discretion, extend the last date for the submission of bids through an announcement of its website

4.4.4 Withdrawal of Bids

No bid will be permitted to withdraw in the interval between the deadline for submission of bids and expiration of the period of bid validity. Withdrawal of bid during this period would result in forfeiture of bidder’s EMD. However, on account of any amendments the Bidder may withdraw their bid after the bid submission prior to the due date (or extended due date, if any) for submission of bid

4.4.5 Disqualified Bids

Price Bids of the technically disqualified Bidders would be returned to them after finalization of the contract under intimation and against acknowledgement from the Bidders.

5.GENERAL TERMS & CONDITIONS (GTC):

A. Terms & conditions governing the bid as follows:

- i) The Bidders, or their authorized representatives, would be permitted to attend the opening of the Tenders. The representatives must carry a letter of authority or any other valid document from the bidders, authorizing them to attend the tender opening, failing to which they will not be permitted to participate in this process.
- ii) Unsigned Bids are liable to be rejected.
- iii) The Bids should be neatly presented. Corrections, if any, should be duly authenticated with full signature of the person who has signed the Bids, failing which such Bids are liable to be rejected.
- iv) AIESL reserves the right to accept or reject any or all offers without assigning any reason.
- v) In the event of default in services, AIESL reserves the right to cancel the order and to claim damages from the successful tenderer, and also reserves the right to award the contract to another vendor at the cost and risk of the successful bidder.



- vi) AIESL shall make payment by an account payee cheque/ Electronic Transfer of funds within 60 days of delivery & installation of material and on submission of bills duly certified by the officer authorized by user dept..
- vii) Deduction of Govt. taxes will be levied as per Govt. rules applicable from time to time.
- viii) No Bid shall be modified after the Due Date/Time for submission of Bids.
- ix) The bidder should ensure that: -
 - The Tender document should be neatly typed and signed on numbered pages filed in binding folder.
 - Corrections/over writing, if any, should be duly authenticated with full signature of the person who is signing the tender (initials will not be accepted)
 - Attached documentary proof in binding folder should be indexed chronologically, labeled and counter signed. Non-Compliance to any of the above shall be liable for tender rejection.

B. DEFINITIONS

- i) In this contract, the following terms shall be interpreted as indicated. "Contract" means the agreement entered into between the Purchase and the Contractor, as recorded in the contract form signed by the parties including all annexure thereto and appendices therein.
- ii) "Goods" or "Items" shall mean all of the equipment including their accessories and /or other materials, which the Tenderer is required to supply to the Purchaser under the contract.
- iii) "Purchaser" or "Buyer" or "Owner" means AIESL, AI Engineering Services Limited.
- iv) "Seller" or "Bidder" means the individual or firm or company, who are manufacturers and suppliers, on whom the order for work is placed and shall be deemed to include their approved successors, heirs, executors and administrators, holding company/Group/Group Companies, Conglomerate as the case may be.
- v) "AIESL representative" means the authorized representative of the purchaser.
- vi) "Manufacturer" means original equipment manufacturer (OEM). "Vendor" means contractor/supplier to the Bidder.

C. PENALTY CLAUSE:

(Non Compliance on Penalty clause terms will lead to disqualification) :-

Prompt, Punctual, Efficient, Safe, Courteous And Quality Service Is The Essence Of This Po. In case of failure on the part of the service provider to comply with any one or more of the terms of the PO, the applicable penalty clauses listed below shall be invoked.

0.5% of the PO value per week to a maximum of 10% of the total value will be levied for non-completion of satisfactory performance of the work within the stipulated time period.

D. PRICE NEGOTIATION:

As it is not the general norm for AIESL to carry out price negotiations following evaluation of the bids (RFQ), the bidders are advised to submit their best quotes in response to this tender. However, AIESL, reserves the right to carry out negotiations in exceptional cases with the bidder who has been evaluated by AIESL as having offered the lowest bid in response to the tender.

E. VALIDITY OF PRICES:

Quotations should be valid for a period of 120 days from the date of technical bids.

F. EXIT CLAUSE/TERMINATION OF THE CONTRACT:

The service provider shall undertake that in the event of failure to complete the job within



the time and according to the requirement and the terms & conditions of the PO, the PO will be liable for cancellation and services will be obtained from other sources on account and at the cost of service provider. The service provider will be fully responsible for any difference in rate and other expenses arising out of such alternate arrangements.

G. AIESL'S RIGHT TO ACCEPT/ REJECT ANY OR ALL BIDS

AIESL reserves the right to accept or reject any bid, and to cancel the bidding process and reject all bids, at any time prior to the award of Contract, without thereby incurring any liability to the affected bidder or bidders. However, the Bidder(s) who wish to seek reasons for such decision of cancellation/ rejection shall be informed of the same by AIESL unless its disclosure reasonably could be expected to affect the sovereignty and integrity of India, the security, strategic, scientific, or economic interest of the state or lead to incitement of an offence.

The bidder whose bid has been accepted will be notified of the award by AIESL prior to expiration of the Bid validity period through the "Letter of Acceptance/ Letter of Award", which will state the sum that AIESL will pay to the Contractor in consideration of the execution, completion by the Contractor as prescribed by the Contract.

The notification of award will constitute the formation of the Contract until the Formal Agreement is signed. The successful bidder shall execute Contract Agreement and sign the Integrity Pact (wherever applicable) with AIESL on non-judicial paper of appropriate value as per Stamp Act in the format appended within 28 days from the date of issue of Letter of Acceptance/ Letter of Award.

H. REJECTION OF BIDS:

The response to the Bidder (RFQ) will be rejected forthwith without evaluation of the tender response on the following grounds:

- i. If the Bidder have been received after due date and time of closing of the tender.
- ii. If the RFQ/BID have been received by fax or email.
- iii. If the RFQ/BID have been received unsigned.
- iv. If the RFQ/BID has been received in an open condition.
- v. The Bidder should ensure that: -
 - The bid document should be neatly typed and signed on numbered pages filed in binding folder.
 - Corrections/over writing, if any, should be duly authenticated with full signature of the person who is signing the tender (**initials will not be accepted**).

I. ZERO DEVIATION

Bidder is advised to quote strictly as per terms and conditions of tender document and not to stipulate any deviation / exceptions / conditions. This is a zero deviation tender.

Bidder to note that taking deviation to following clauses of tender documents shall lead to rejection of their bids:

- i. Firm Price and award criteria
- ii. EMD
- iii. Scope of Work
- iv. Special Conditions of Purchase order
- v. Delivery Schedule strictly before 1400 hrs within 60 Days from award of contract.
- vi. Period of Validity of Bid 120 Days



- vii. Performance Bank Guarantee / Security Deposit
- viii. Guarantee of work / Services / equipment
- ix. Arbitration / Resolution of Dispute
- x. Force Majeure
- xi. Statutory Compliance to Applicable Laws
- xii. Any other condition specifically mentioned in the tender documents elsewhere that non-compliance of the clause shall lead to rejection of the bid.

J. ARBITRATION:

Any dispute arising between the parties in respect of the construction, interpretation, application, meaning, scope, operation or effect of this document or the validity or breach thereof, shall first be settled by mutual consultation. If the dispute remains unresolved after a period of 90 days from the date when the mutual consultation has started, the matter shall be referred for settlement to 'SCOPE FORUM OF CONCILIATION AND ARBITRATION', Govt. of India, and the award made in pursuance thereof shall be binding on the parties

K. FRAUDULENT PRACTICES:

AIESL requires that Bidders observe the highest standard of ethics during the Bidding process and execution of contracts. In pursuance of this, AIESL defines, for the purposes of this provision, the terms set forth below as follows:

- a) "Corrupt practice" means the offering, giving, or soliciting of anything of value to influence the action of a public official in the procurement process or in contract execution.
- b) "Fraudulent practice" means a misrepresentation of facts to influence a procurement process, or the execution of a contract deemed to be detrimental to AIESL and includes collusive practice among Bidders (prior to or after Bid submission) designed to establish Bid prices at artificial non-competitive levels and to deprive AIESL of the benefits of free and open competition.
- c) EMD or Security deposit shall be forfeited in addition to the above-mentioned remedies which AIESL shall have taken.

L. BLACK LISTING CONDITIONS:

The party shall be black listed from participating in any AIESL tenders for next three years in case adopts fraudulent practices as cited above in clause and against errant bidders as specified in clause. Withdraws after award of the Purchase order / Letter Of Award (LOA) and fails to commence within the specified stipulated period and perform the contractual obligations during the currency of the Purchase order.

M. INTERPRETATION OF AMBIGUITY:

If the contractor needs any clarification as to the scope of the "agreement", and other conditions of contract, the contractor is at liberty to get them clarified before quoting tender rates.

N. FORCE MAJEURE:

Neither party shall be liable for delay in performing obligations or for failure to perform obligations if the delay results from any of the following (whether happening in India or



elsewhere) force majeure, Act of God or any Governmental act, fire, earthquake, explosion, accident, industrial dispute, civil commotion, or anything beyond the control of either party. The party shall use all reasonable endeavors to minimize any such delay. Upon cessation of the event giving rise to the delay the parties shall in so far as may be practicable under the circumstance

O. JURISDICTION:

Any dispute whatsoever shall be subject to the jurisdiction of the courts of New Delhi, India, only.

P. INTERPRETATION OF AMBIGUITY:

If the contractor needs any clarification as to the scope of the “agreement”, and other conditions of contract, the contractor is at liberty to get them clarified before quoting tender rates.

Q. PAYMENT TERMS (Non acceptance of Payment terms will lead to disqualification) :-

100% payment upto 45 days of submission of invoice or receipt of goods, whichever is later after commissioning of the equipment (commissioning to be carried out within 15 days from the date of receipt of Equipment/items). Normally advance payments will not be accepted, however, if required may be done only against suitable Bank Guarantee, for which bidder must bear the charges.

Mode of Payment

Payment will be made through ECS mode. Kindly provide the following information:

- Account Name
- Name of the Bank
- Branch Name
- Account Number
- Bank Code/MICR No.
- Swift Code No.

R. COMMERCIAL TERMS:

EARNEST MONEY DEPOSIT (EMD):

- i) An Earnest Money Deposit of Rs. 38,000 /- (Thirty-eight Thousand only) (only INR **currency acceptable**) must be submitted by means of Bank Draft or Banker’s Cheque in favor of AI ENGINEERING SERVICES LIMITED, payable at DELHI, and should be submitted along with the technical bid.
- ii) EMD will not carry any interest.
- iii) EMD in respect of successful bidder will be adjusted against Security Deposit.
- iv) If above, bid received without EMD or lesser amount of EMD or received in different mode, will be rejected.
- v) In case, the selected bidder refuses to accept the LOA/Contract OR fails to abide by any terms of the Tender/fails to commence the work within stipulated time, EMD shall be forfeited.
- vi) In case of selected bidder, EMD can be adjusted in SD as a special case.
- vii) In case of unsuccessful bidders, EMD shall be refunded without interest, within a reasonable time after finalization of the Tender.
- viii) **If EMD Bankers DD not enclosed will lead to disqualification, applicable to Non MSME/NSIC bidders only.**
- ix) **MSME/NSIC must enclose Certificate to claim exemption.**



S. Benefits/Preference for Micro & Small Enterprises (MSEs):

As per Public Procurement Policy for Micro & Small Enterprises (MSEs) Order, 2012 issued vide Gazette Notification No.503 dated 23.03.2012 by Ministry of Micro, Small and Medium Enterprises of govt. of India, MSEs must be registered with any of the following in order to avail the benefits/preference available vide Public Procurement Policy MSEs Order, 2012.

- District Industries Centres (DIC)
- Khadi and Village Industries Commission (KVIC)
- Khadi and Village Industries Board
- Coir Board
- National Small Industries Corporation (NSIC)
- Directorate of Handicraft and Handloom
- Any other body specified by Ministry of MSME

i) MSME Price Preference-

The MSMEs registered with above mentioned agencies/bodies for the Tendered Service/Equipment supplier and quoting price within price band of L1+15% (fifteen per cent) shall also be allowed to supply **COMPLETE EQUIPMENT AS PER WORK SCOPE** by bringing down their price to the price quoted by L1. In case of more than one such MSMEs are in the price band of L-1 + 15% and matches the L-1 Price, **COMPLETE EQUIPMENT AS PER WORK SCOPE**.

ii) An MSE unit will not get any purchase preference over another MSE unit.

Note: Above policy of extending benefits is meant for procurement of only goods produced and services rendered by MSMEs and not for any trading activities by them.

T. EXEMPTION FROM EMD :

- iii) As per Govt of India Gazette Notification No. 5031, dated 26.3.2012, MSME's registered with District Industries Centres / KVIC's/ KVIB's/ Coir Board/ NSIC/Directorate of Handicrafts and Handloom or any other body specified by Micro, Small & Medium Enterprises (MSME), are exempted from payment of EMD. Valid certificate of registration with as above, must be provided by the bidder(s) seeking exemption of EMD. Public Sector units/Central/State Govt. undertakings/units registered with central purchase organization (eg. DGS&D) will be exempted from submission of EMD.**
- iv) Bidder must be registered in same services to claim the exemption.**
- v) MSEs participating in the tender must submit the certificate of registration with any one of the above**
- vi) agencies indicating the details of the tendered item along with their bid.**
- vii) The MSEs registered with District Industries Centres must submit the Acknowledgement of Entrepreneur Memorandum (EM) Part-II along with their bid. The MSEs registered with National Small Industries Corporation (NSIC) must submit the valid NSPC registration certificate along with their bid. The Micro and Small Enterprises not registered for the trade/item for which this tender is relevant, would not be eligible for exemption / preference.**
- viii) The registration certificate issued from any one of the above agencies must be valid as on close date of the tender. The Successful Bidder should ensure that the same is valid till the end of the Contract period.**
- ix) The MSEs, who have applied for registration or renewal of registration with any of the above agencies/bodies but have not obtained the valid certificate as on close date of the tender, are not eligible for exemption / preference.**

- x) Exemption from submission of EMD – The MSEs registered with above mentioned agencies/bodies are exempted from payment of EMD.
- xi) The Successful Bidder (MSME/Non MSME) will be required to submit the Security Deposit as
- xii) applicable on the Contract value. However, in case of MSE Bidders, the Security Deposit/Bank Guarantee can be submitted on yearly basis renewable every year.

**U. PERFORMANCE BANK GUARANTEE (PBG) / SECURITY DEPOSIT:
(Non-Compliance on SD/PBG terms, as below will lead to disqualification)**

- i) The bidder who qualifies for award of PO will have to deposit with AIESL, **5%** of the total value of the Purchase Order towards PBG / Security Deposit, within **two weeks** of receipt of the Purchase Order. The Security Deposit is to be paid by a Bank Draft or Banker's Cheque in favor of the "AI Engineering Services Limited", payable at Delhi, or by execution of a Bank Guarantee for an equivalent amount. The expenses incurred towards submission of Security Deposit / Bank Guarantee will have to be borne by the bidder and no interest will be payable on submission of SD in the form of banker cheque and Demand Draft.
- ii) The Security Deposit / Bank Guarantee will be refunded / returned after 60 days of successful completion of warranty period against the Purchase Order after adjusting for penalties, if any, that may be imposed under the terms of the Purchase Order.

6.SPECIAL TERMS & CONDITIONS(STC): -

• **Warranty:**

Warranty (**Non Compliance on Warranty terms will lead to disqualification**) :-

Warranty of **One** years from the date of commissioning against all materials/workmanship defects for the unit as well as for the bought-out items.

Standard **One** year Warranty should include free servicing and comprehensive parts and consumables (if any as and required). The warranty must cover equipment installed at premises.

For any warranty related issue, the Bidder should respond within **24 Hours**. If any complaint/fault occurred in machine unattended beyond **72 Hours** shall attract a penalty of 0.5% per week of submitted SD/PBG. Depleted amount with regard to SD/PBG need to be topped up with in fifteen days by the Bidder.

Annual Maintenance Contract (AMC) or Extended Warranty (EW) – AIESL desires to have AMC / Extended warranty **for 2 years**, post completion of standard warranty period of one year. The Comprehensive AMC / EW should cover for the maintenance cost inclusive of consumables, and materials. Comprehensive AMC / EW.

Maintenance schedule must be provided by the Bidder, Bidder should ensure that these inspections should be simplified which can be performed even by an operator or a driver.

• **Quality Assurance Certificate**

Every supply should be accompanied with a Quality Assurance Certificate (QAC) indicating that the goods so supplied are in conformity with the specifications given in the Purchase Order.

• **In house inspection**

AIESL reserves the right to inspect Equipment/ item at any stage before accepting. In case, any deviation in quality is found at the time of supply, then the same will be rejected and should be replaced free of cost. Non adherence of this clause may lead to



cancellation of P.O and AIESL reserves the right to withhold the invoice for that shipment.

7.AWARD DECISION FOR L1

Splitting of PO is allowed with respect to lowest bids received either for HVLS fans or Industrial Coolers.

The Bidder whose net price works out to be the lowest for each section (refer price bid Annexure B) will be determined as L1 for that line item/s **Section 1 or Section 2** and order will be placed on lowest quote basis accordingly.

Section 2.1 is added contingency bidders are requested submit their lowest quote only, however it is optional if AIESL desires from OEM/Mfr./Supplier.

The NET PRICE shall be determined based on **DAP** Cost (per Unit Cost) with Standard(inclusive) one year warranty cost.

- MSME Price Preference- The MSMEs registered with above mentioned agencies/bodies for the Tendered Service/Equipment supplier and quoting price within price band of L1+15% (fifteen per cent) shall also be allowed to supply COMPLETE EQUIPMENT AS PER WORK SCOPE by bringing down their price to the price quoted by L1. In case of more than one such MSMEs are in the price band of L-1 + 15% and matches the L-1 Price, COMPLETE EQUIPMENT AS PER WORK SCOPE.
- An MSE unit will not get any purchase preference over another MSE unit.
Note: Above policy of extending benefits is meant for procurement of only goods produced and services rendered by MSMEs and not for any trading activities by them.

POINT OF CONTACT/CLARIFICATION: -

Single point contact to be provided by the bidder along with email ID and telephone number of the contact person for any clarification during tender process.

1. Mr.Namit-Dy..G.M. (AIESL) Technical
2. Mr.Sanjay Meena - Commercial

Email ID: aieslpurchase.nr@aiesl.in

Ph. No. 011-25667714/7825

Details of authorize representative submitting the bid (furnish data below mandatory).

Name:
Designation:
Mobile No.:
Office Address:
Email Address:

8. TECHNO COMMERCIAL BID

ANNEXURE A

S. No.	Description	Indicate Compliance Along with information



1	<p>a) The Bidder must be OEM, distributor in same business for at least last (02) years i.e. on or before 31st March 2023. Supporting document in form of either purchase order or commissioning report or invoice on or before 31st March is to be submitted. Should have supplied a minimum of two orders to Limited Group companies or Maintenance Repair Organization or reputed Organizations.</p> <p>b) Certified acknowledgement copy of Income Tax returns, computation of ITR, balance sheet and profit & loss account for FY 2020-21, 2021-22 & 2022-23. Further, income tax return for FY 2020-21, 2021-22 & 2022-23.</p>	<p>PO/Commissioning report: 1. MANDATORY 2. MANDATORY</p> <p style="text-align: center;">Mandatory 1.FY 2020-21 2.FY 2021-22 3.FY 2022-23</p>
2	<p>EMD in form of Bankers DD to be submitted along with Technical Bid. (NSIC/MSME must enclose Cert to claim exemption. Foreign bidders can do electronic transfer (refer COMMERCIAL TERMS)</p>	<p>Mandatory to Non MSME/NSIC</p>
3	<p>Bidder should be a registered company/firm in existence for at least (03) years. OR, If Consortium, then furnish details of partners. Each partner of the consortium shall be a registered Company/firm in existence for at least past (03) years. Certificate of Company registration to be provided. Consortium Agreement and along with company registration certificate of partner companies to be provided.</p>	<p>Registration No(s) and year of registration. Consortium Agreement date Mandatory</p>
4	<p>Minimum Average Annual turnover of the Bidder for 3 last 3 financial year i.e. on or before 31st March 2023. (as applicable) should be minimum of Rs.18 Lac. (refer Annexure E)</p>	<p>Turnover-3 year wise (Currency to be reflected)</p>
5	<p>As on date of submission of the tender, the Bidder or its parent company or subsidiary, or a group company should not have been black listed / debarred by AIESL or any of the State or Central Government of India or any Organization of State or Central Government of India. Under taking by the Bidder to be submitted.</p>	<p>Mandatory</p>
6	<p>Bidder must enclose soft copies of PAN (Company), GST Reg. (Annex A & B), MSME Cert (If any). Incorporation Certificate/ deed</p>	<p>Mandatory</p>
7	<p>Delivery Period (must be inclusive of commissioning)</p>	<p>01 Month(Mandatory)</p>

8.a	Technical Specification for HVLS Fan	Comply
------------	---------------------------------------------	---------------

1	Type of Fan	Gearless PMSM HVLS Fan (Mandatory)	Yes/No
2	Air Flow Volume (cfm)	4,88,000 CFM or equivalent	_____CFM
3	Fan Size	24 feet (Mandatory) Front 16 Feet (Mandatory) Rear	Yes/No
4	Electricity Consumption	1.2 KW	Yes/No
5	Motor Make	EMF PMSM Gearless High Efficiency Motor (Mandatory)	Yes/No
6	Noise (db)	< 35db	_____dB
7	Operation Manual (English Language Mandatory)		
8	Fan mounting must be with Guy wire for stability or equivalent method is to be used to ensure safety. (Mandatory)		Yes/No

Fill data by Yes/No in third column (Mandatory).

Note: Bidder must meet mandatory conditions as requested above.

Specification's for HVLS fans

1. Supply of 4 sets of HVLS fans with necessary structural brackets, cable, cable tray, guy wire
2. Temporary hiring of lifting equipment (hydra/boom lift)
3. Installation of 4 sets of HVLS fans
4. Installation of control panel with cabling up to each HVLS fan.
5. Installation & Commissioning along with operator training.

8.b Typical Technical specifications for Industrial Coolers

1	Description	Rating required	Furnish Data
2	Airflow Capacity	25000 M3/H Equivalent (Mandatory),	Mandatory -Capacity must be greater or equal to 25000 M3/H
3	Power	2.2 kW	
4	Pressure	306 Pa (Desired)	
5	Net Weight	Mention weight in Kg	
6	Vent Size LXW	Mention dimensions in mm	
7	Dimension LXWXH	Mention dimensions in mm	
8	Pad Size LXWXH	Mention dimensions in mm	
9	Rated Currency	5.4A	
10	Fan Type	Axial (Mandatory),	
11	Fan Speed	3-Phase, Multi-Speed (Mandatory)	
12	Frequency	50 Hz	

Fill data by Yes/No in third column

Short listing criteria bidder must comply with field where it has been marked as (Mandatory).

Note:

- All above Documents/Certificates must be submitted in English language.
- Any column left blank may lead to **disqualification**, hence it mandatory to fill details as requested.
- Non-compliance of any of the above clause or remarks like noted, agreed, ok, etc is liable for disqualification in Tech.-comm. bid. Wherever it has been marked Mandatory bidder must comply with specifications as requested otherwise bids will be rejected / disqualified.
- Supporting documents/certificate related to should be labeled, countersigned and attached with end of tender document properly numbered.

Signature & Seal of Bidder

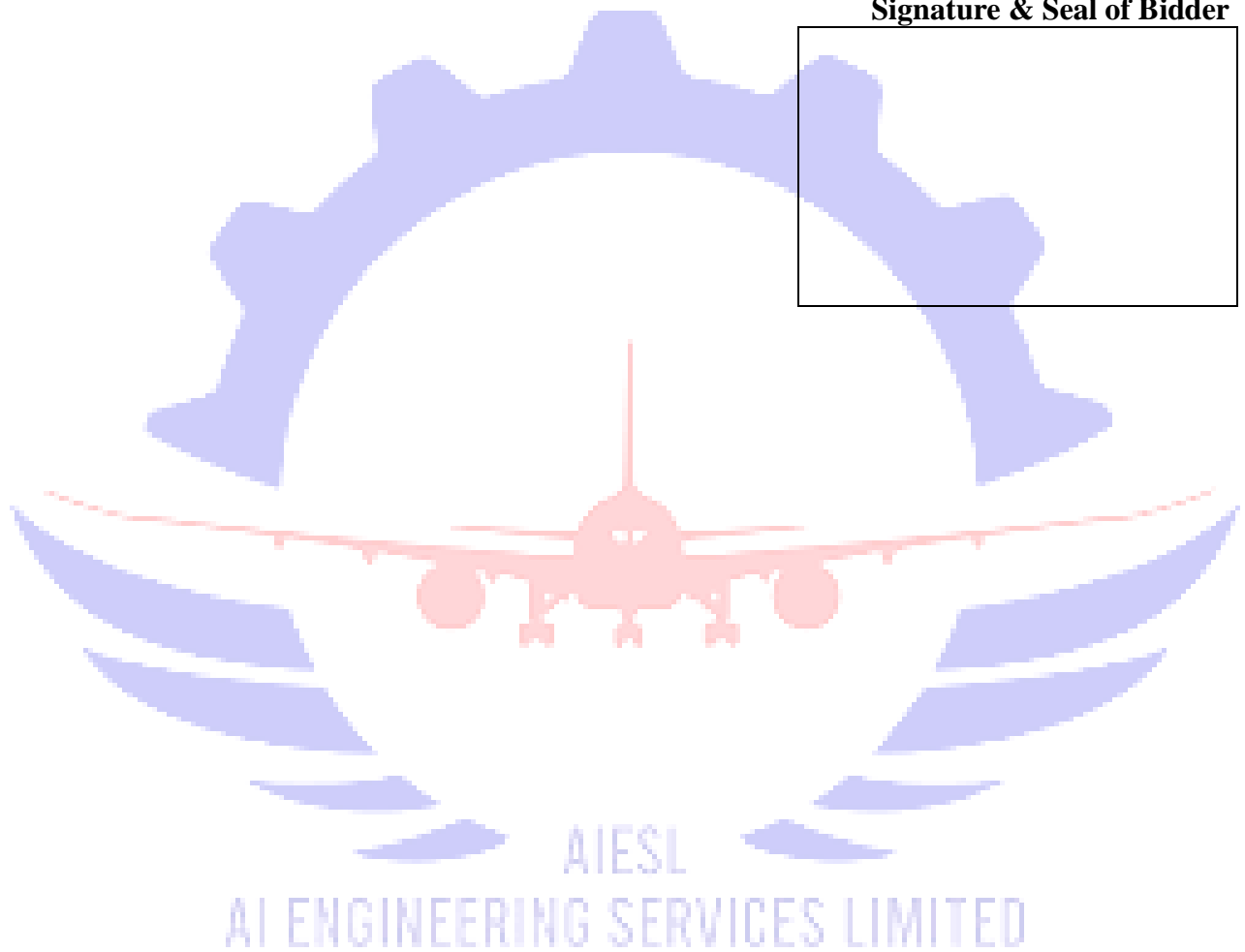
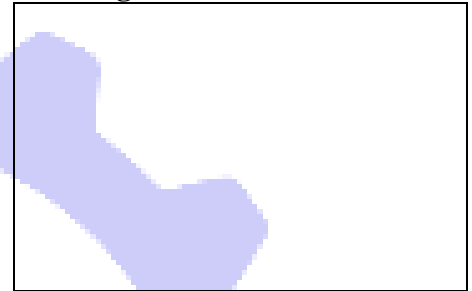

9. PRICE BID (Price Bid Format)



ANNEXURE-B

To,
The GM (ENGG.)
The GM (ENGG.)
AI ENGINEERING SERVICES LTD,
NEW AVIONICS COMPLEX,T-II,
IGI AIRPORT,DELHI-110037,India.

Subject: Price Bid for supply of HVLS fans and industrial coolers.

Section 1 - HVLS Fan

Rate per Fan for 24 Feet	Rate per Fan (INR only) (In Figures)
Rate per Fan for 16 Feet	(In Figures)
Inclusions to above rate: Fan, Control Panel, Cable, Cable Tray mounting bolts, guy wire etc., MCB, 100- meter wiring (each). The rate must be inclusive of Installation, Inland Transportation & other local costs for all Equipment incidental to delivery at Hanger No.2, NEW DELHI. Including one year warranty. Specify warranty if standard warranty is more than one year=Years	Included in above rate.
GST @ 18%	INR
GRAND TOTAL (Section 1) For Four HVLS fans	INR (In Figures) (In words)

Rates quoted in GRAND TOTAL (Section 1) will be considered for price bid evaluation for section -1

Section 2 - Industrial Coolers

Industrial Coolers with 1Foot Stand & with 10 feet Duct (18x18 inch) each with MCB, regulator & 60 meter wiring in conduit (Each). Rate must be inclusive of Installation, Inland Transportation & other local costs for all Equipment incidental to delivery at Hanger No.2, NEW DELHI. Including one year warranty	Rate per Cooler (In Figures) (In words)
GST @ 18%	INR
GRAND TOTAL (Section 2) FOR SIX INDUSTRIAL COOLERS	INR (In Figures) (In words)

Rates quoted in GRAND TOTAL (Section 2) will be considered for price bid evaluation for section 2.

Section 2.1 Additional Consumables for cooler ducting.

Rate for wiring Rate/meter	INR
Ducting per running length (18x18) inch	INR
GST @ 18%	INR
TOTAL	INR (In Figures) (In words)

Section 2.1 is optional however it is mandatory to provide lowest quote. It will not be criteria for L1.

Undertaking

I/We hereby declare that I/We have read and understood the scope of work & description of work, terms and conditions of the contract and hereby agree to abide by the same.

Price Bid Terms & Conditions:

- Rate quoted by local (Indian Bidders) should be INR only.
- Rates should include all taxes payable to authorities.
- In case of discrepancy between unit price and total price, the unit price shall prevail.
- In case of discrepancy between figures and words, the price in words shall prevail.
- **Award of Contract:**
 - a) Splitting of PO is allowed with respect to lowest bids received either for HVLS fans or Industrial Coolers.
 - b) The Bidder whose net price works out to be the lowest will be determined as L1 for that line item/s **Section 1 or Section 2** and order will be placed on lowest quote basis accordingly.
 - c) **Section 2.1** is added contingency bidders are requested submit their lowest quote only, however it is optional if AIESL desires from OEM/Mfr./Supplier.
- The NET PRICE shall be determined based on **DAP** Cost (per Unit Cost) with Standard(inclusive) one year warranty cost.
- MSME Price Preference- The MSMEs registered with above mentioned agencies/bodies for the Tendered Service/Equipment supplier and quoting price within price band of L1+15% (fifteen per cent) shall also be allowed to supply COMPLETE EQUIPMENT AS PER WORK SCOPE by bringing down their price to the price quoted by L1. In case of more than one such MSMEs are in the price band of L-1 + 15% and matches the L-1 Price, COMPLETE EQUIPMENT AS PER WORK SCOPE.
- An MSE unit will not get any purchase preference over another MSE unit.
Note: Above policy of extending benefits is meant for procurement of only goods produced and services rendered by MSMEs and not for any trading activities by them.
- Taxes and other levies/ charges shall be payable as per actual at applicable rates.

Signature of Bidder

If AIESL desires to have Extended Warranty from OEM/Distributor for supply of HVLS FANS AND INDUSTRIAL COOLERS (quote separately in same prescribed format)

Table B

S.No	Rates For Extended Warranty / AMC With Consumables	To be quoted in INR
i	FOR 1 st YEAR (EXCLUDING WARRANTY PERIOD OF 1 YEAR)	
ii	FOR 2 nd YEAR (EXCLUDING WARRANTY PERIOD)	
B	GRAND TOTAL:(i + ii) B	
	IN WORDS:	

Note: Table B is optional if AIESL desires from OEM/Mfr./Supplier. However bidders are requested submit their lowest quote only.

Signature & Stamp of the Bidder



10.DECLARATION (To be given on Company's Letter Head)

ANNEXURE-C

Date

To,
**The GM (ENGG.)
AI ENGINEERING SERVICES LTD,
NEW AVIONICS COMPLEX,T-II,
IGI AIRPORT,DELHI-110037,India.**

Dear Sir

Ref: Tender No.....

I/We,..... hereby confirm that our Firm/Company /Group/Group Company has not been black listed / debarred by Air India / AIESL or any of the State or Central Government of India or Organization of State or Central Government of India.

Place: Signature of Bidder.....

Date: Name

Designation.....

Seal/Stamp

AIESL
AI ENGINEERING SERVICES LIMITED



11.UNDERTAKING from bidder (Bidders Letterhead)

ANNEXURE D

To,
The GM (ENGG.)
AI ENGINEERING SERVICES LTD,
NEW AVIONICS COMPLEX,T-II,
IGI AIRPORT,DELHI-110037,India.

Date:___dd-mm-yyyy

Sir,

Having examined the bidding documents, I/we undersigned, offer to supply and deliver (description of goods / services) in conformity with the said bidding documents as per the prices given in the price bid. We undertake, if our bid is accepted, to commence and complete delivery of all the items in specified delivery period as mentioned in the tender from the date of receipt of PO/LOA.

I/We agree to abide by this bid for a period of 120 days from the date fixed for last date of bid submission and it shall remain binding upon us and may be accepted at any time before the expiration of that period. Until a formal purchase order is prepared and executed, this bid, together with your written acceptance thereof, shall constitute a binding contract between us.

Dated_____day of_____2023

AIESL
AI ENGINEERING SERVICES LIMITED

Name & Signature of the Bidder

.....

Annexure E

12.Chartered Accountant's Certification For Turnover
(To be given on company letterhead)

I, _____ C.A (Name) _____ membership number _____
Have verified the P&L account, balance sheet, Income details as per the documents /records Submitted for verification and hereby certify that the Turnover of M/s. _____ (the Bidder's name) for the last three

Years for services as mentioned below:

- 1)
- 2)
- 3)

Signature of C.A _____

Seal _____

Date: _____

Place _____

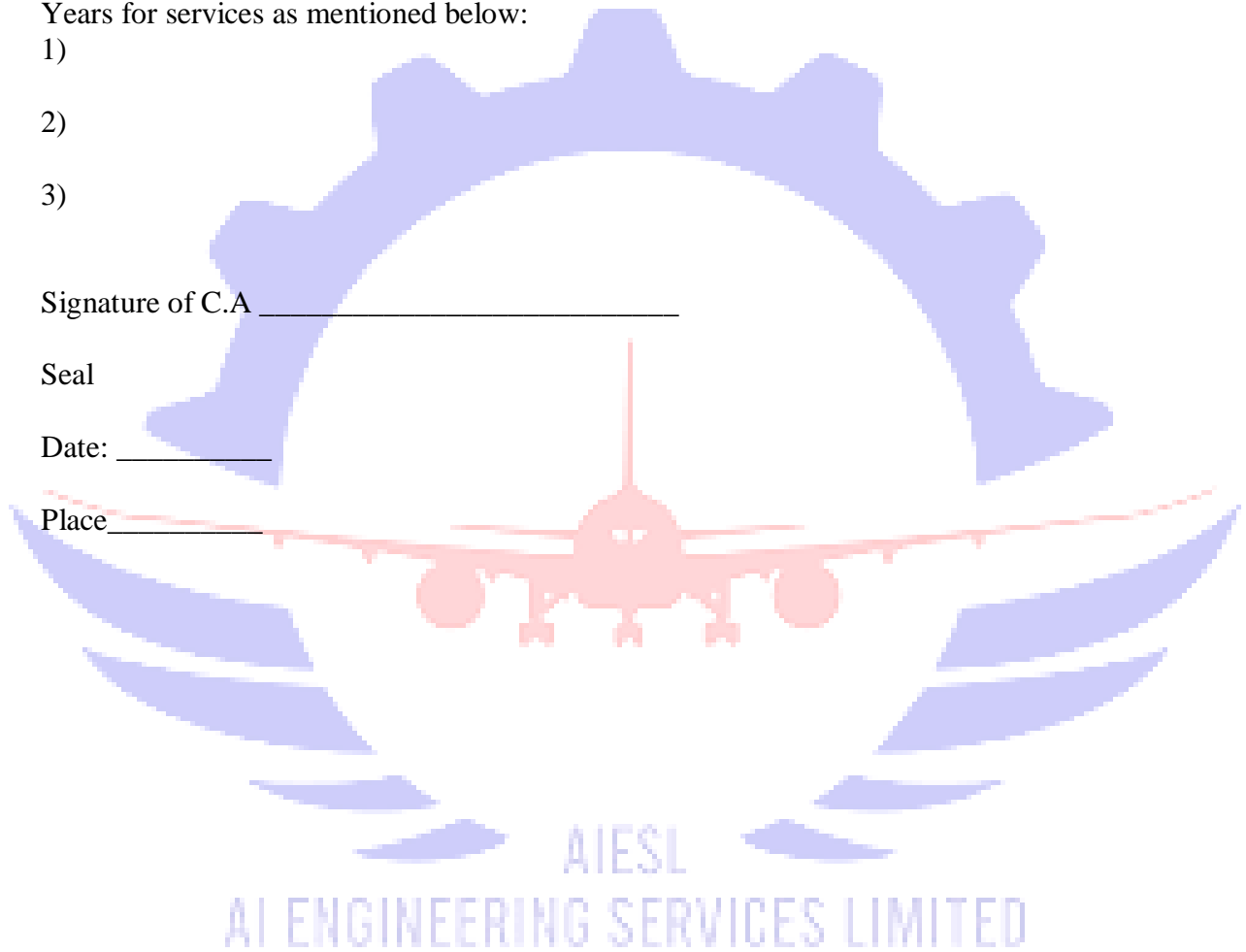

13. Layout Plan HVLS CONCEPT

Annexure F

Drawing No.1

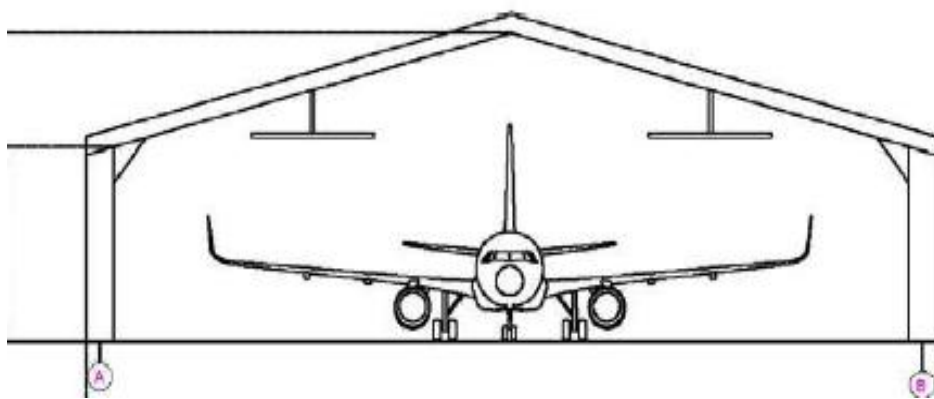
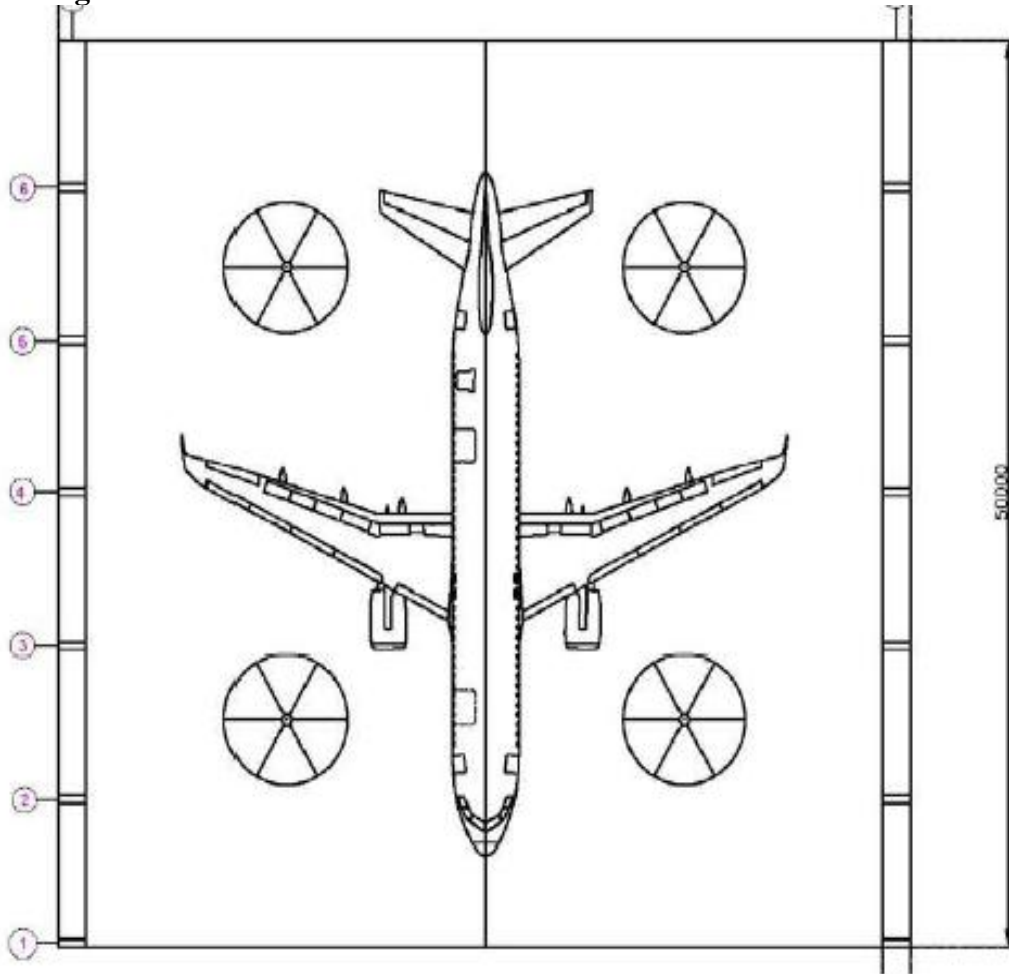

Drawing No.2

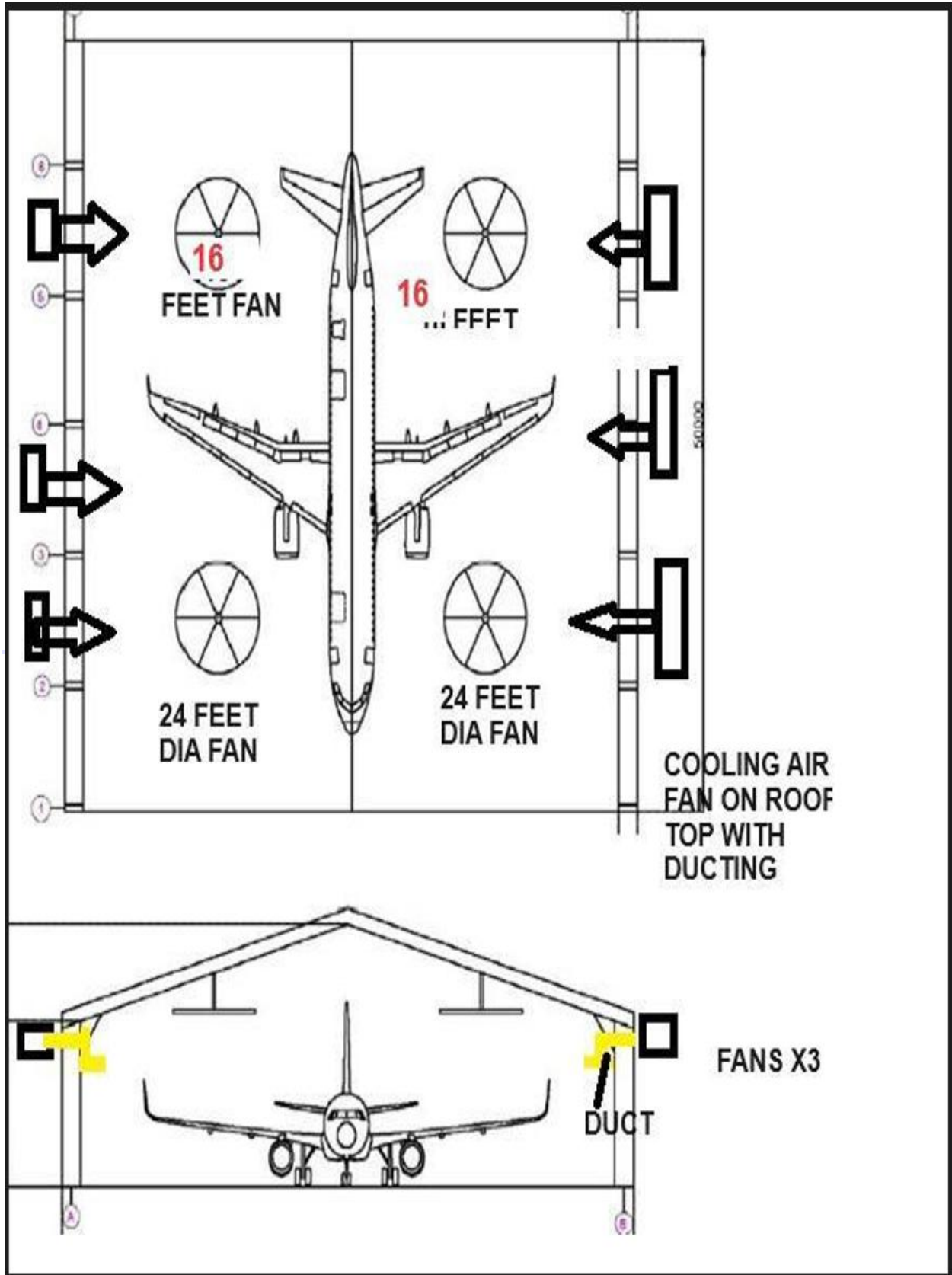

Total 4 ceiling Fans and 6 Industrial Coolers

INDUSTRIAL COOLER INSTALLATION LOCATIONS (TOP VIEW)
Drawing No.3

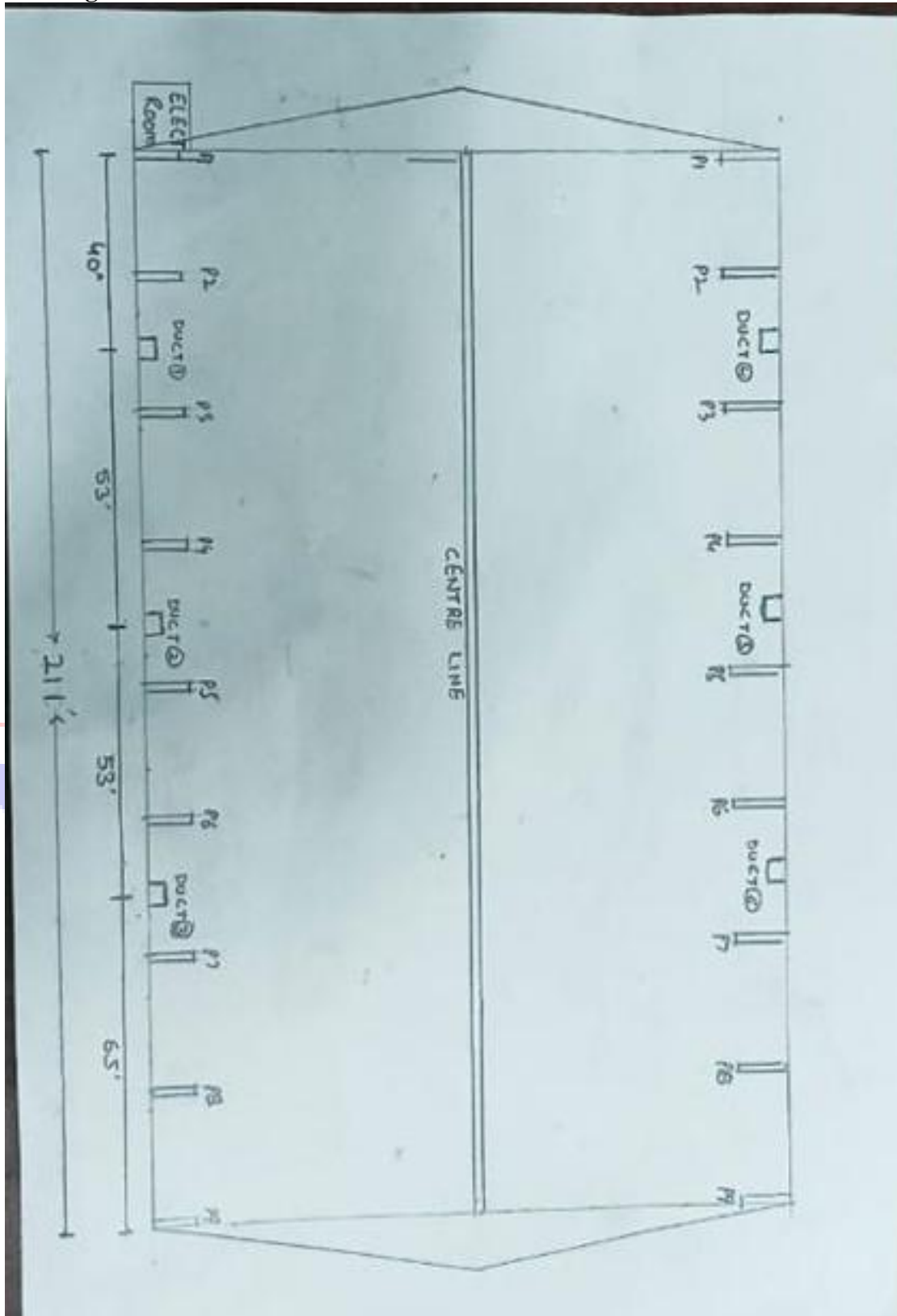

DUCT DESIGN
Drawing No.4

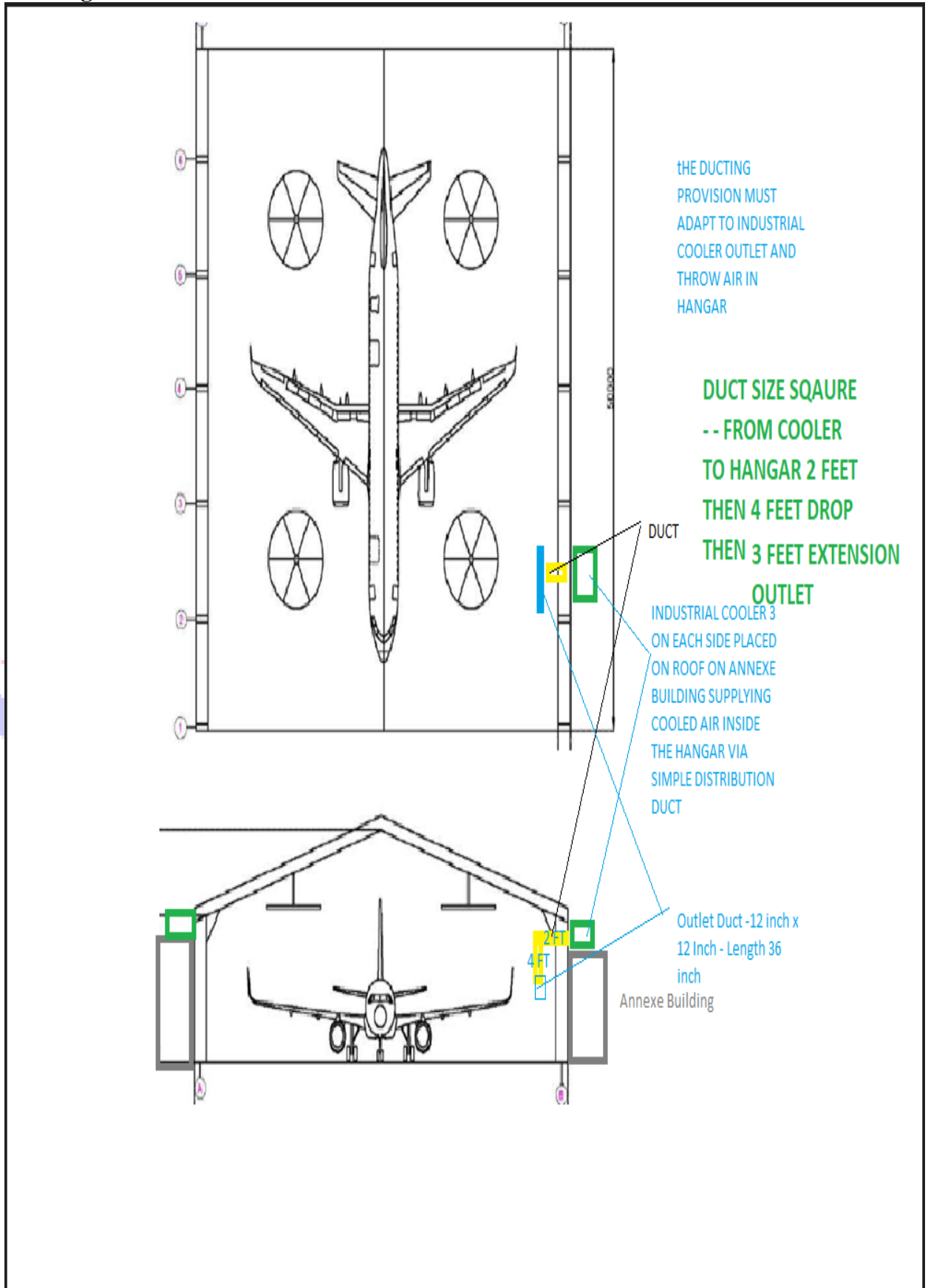



Authorization Letter For Attending Bid Opening (To be given on company letterhead)

To,
GM-Engg.,
A320 New Avionics Complex,
AI Engineering Services Limited,
Indira Gandhi International Airport, Terminal- 2,
New Delhi – 110037.

Sub: Authorization for attending bid opening.

Tender No

Tender Name:

The following persons(s) are hereby authorized to attend the bid opening for the subject tender mentioned above on our behalf.

S.No	Name	E-Mail	Contact No.	Signature
1.				
2.				

Note:

1. Permission for entry to the hall where bids are opened may be refused in case authorization letter as prescribed above is not received.
2. The authorized representatives, in their own interest, must reach the venue of bid opening well in time.
3. The authorized representative must carry a valid photo identity.
4. Without this letter bidder's representative will not be allowed for entry.
5. Carry separately do not enclosed in sealed tender document.

Authorized Signatory
With SEAL

AIESL

AI ENGINEERING SERVICES LIMITED